

3-IN-1 BATHROOM HEATER & EXHAUST FAN WITH TRICOLOUR LED LIGHT



Model Numbers

MBHN2LW

Features

- Low profile design to suit any bathroom application
- High efficiency DC motor
- Polypropylene housing with Polycarbonate fascia
- Built in thermal overload protection
- Back draft stopper included
- Cut-out template included
- Compatible with Martec bathroom remote MBHRKIT (not included)

DIMENSIONS

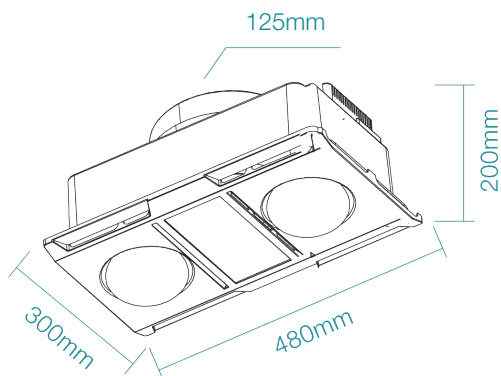

SHIPPING

Model Numbers	Carton Size			Carton Quantity	Carton Gross Weight (Kg)
	H (mm)	W (mm)	L (mm)		
MBHN2LW	590	535	430	2	

AVAILABLE COLOURS



Model	Colour	Barcode
MBHN2LW	White	

SPECIFICATIONS

Model Name	Profile Panel DC 2
Model Numbers	MBHN2LW - White
Air Extraction m ³ /hr	460m ³ /hr
Exhaust Fan Wattage	25W
Voltage / Frequency	220-240Va.c. 50-60Hz
Materials / Housing	Polypropylene
Cutout Size	435 x 255mm
Decibel Rating	≤50dB
IP Rating	IPX4
Heating Wattage / Type	2x 275W heat lamps
Lighting Wattage / Type	12W LED
Colour Temperature	3000K / 4000K / 5000K
Lumens Output	850lm / 900lm / 950lm
Minimum Ceiling Depth	220mm
Ducting Size	125mm
Accessories Included	1x 3m duct 2x clips for ducting 1x external grille 1x 3 gang switch wall controller 2x heat lamps

INSTALLATION

Installation	By licensed electrician only
Warranty	2 year in-home warranty

*For further information regarding warranty terms and conditions, please refer to enclosed warranty statement. Warranty is void unless installed by a licensed electrician.