

INSTALLATION GUIDE

Uno Single Lamp Heater

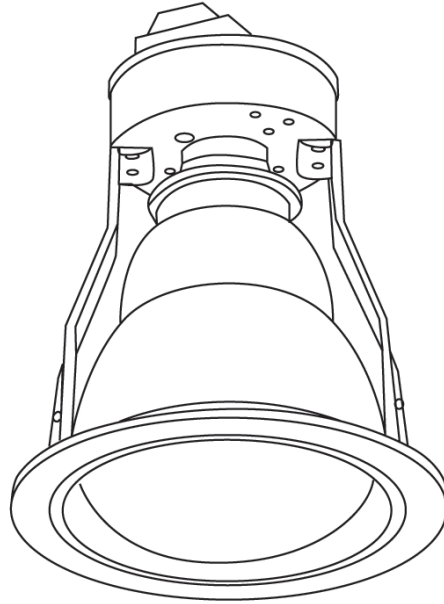

Product Code:

MBHU1LW Uno 1 Single Heat Recessed Ceiling Bathroom Heater Unit Only White

CAUTION
READ INSTRUCTIONS
CAREFULLY FOR SAFE
INSTALLATION



**MUST BE
INSTALLED BY
A LICENSED
ELECTRICIAN**

INSTALLATION

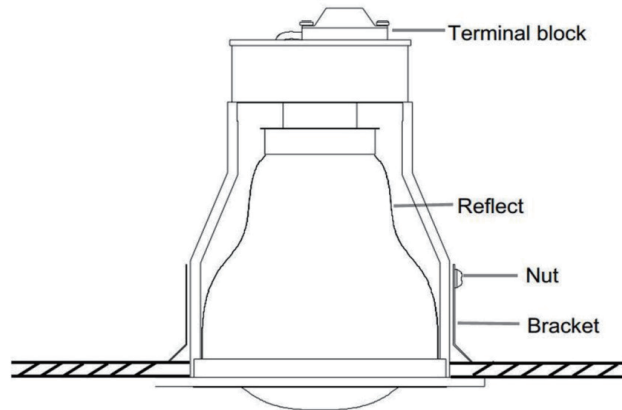

- Step 1. Inspect ceiling cavity to ensure that electrical sub circuit wiring, water pipes and other services as well as ceiling timbers are well clear of the intended position of the single lamp heater
(NB: Ensure there is sufficient clearance above the terminal block housing for two storey house)
- Step 2. Use template provided to cut a circular hole with a diameter of 145mm
- Step 3. Remove packaging before installation
- Step 4. Connect cables
- Step 5. Be sure to replace the cover over the terminals
- Step 6. Insert the light bracket into the hole
- Step 7. Loosen the nut and move the bracket supplied to fix the light firmly into place. Tighten the nut.
- Step 8. Replace the reflector cone and the lamp

WIRING

Fg.1



Remove cover from terminal block

Fg.2

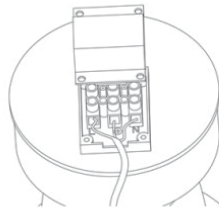

Insert active, neutral and earth wires and tighten the terminal screws

Fg.3



Replace cover from terminal block

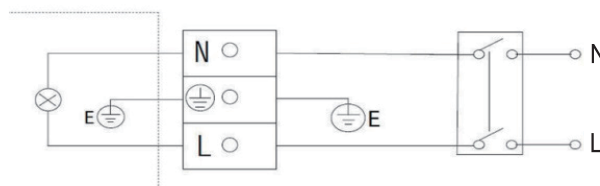

IMPORTANT NOTICES

Features

- Attractive, flush fitting units that scarcely protrude below the ceiling
- Allows installation where the heat is required; above the drying area or above the vanity or elsewhere depending on the bathroom layout
- A semi-gloss white powder-coated rim surrounding the incandescent mirror reflector

WARNING

- Installation of product MUST follow SAA standards and meet local authority regulations
- Installation MUST be carried out by a qualified and licensed electrician
- Warranty will be VOID if the unit has been tampered with damaging by accident, short circuited, loaded beyond rating or damaged otherwise by improper operation
- The warranty is VOID if product is not installed according to this installation guide
- This heater must be installed at a high level, generally not less than 1.8 m above the floor, in accordance with local regulations.
- The heater must be installed so that switches and other controls cannot be touched by a person in the bath or shower.
- This heater is intended for ceiling installation only.
- Under no circumstances must the heater be covered with insulating material or similar materials.
- The appliance is not to be used by persons (including children) with reduced physical, sensory or mental capabilities, or lack of experience and knowledge, unless they have been given supervision or instruction.
- Children being supervised not to play with the appliance.
- Shall state that the heater must not be located immediately below a socket outlet.
- WARNING: The heater must not be used if the glass panels are damaged.
- To ensure the safe use of this product, the full power disconnection function must be incorporated into the fixed wiring design in accordance with the electrical safety regulations. This complies with the requirement in Clause 7.12.2 of the AS/NZS 60335-1 standard regarding the minimum electrical safety level to achieve this standard. At the same time, corresponding operations must also be carried out in accordance with the local wiring standards of AS/NZS3000.
- Regulations concerning the discharge of air have to be fulfilled.
- Joists, beams and rafters shall not be cut or notched to install the appliance.

CLEANING & MAINTENANCE

- Switch off the power supply before cleaning and allow the lamp to cool down.
- Wipe the lamp and front fascia regularly with a soft, dry cloth.
- Do not use abrasive cleaners or solvents.

WARRANTY INFORMATION

1 Year Replacement Warranty

For further information please visit our website (link below) OR scan the QR code.

<https://www.martec.com.au/warranty-statement>



For technical support, please contact Martec customer service hotline at **(02) 8778 7500**.

If you suspect any issues with the installation, please contact your installer to resolve the matter. In case you believe the issue is related to a manufacturing defect, you can file a warranty claim by visiting

<https://www.martec.com.au/warranty-claim-form> or scan the below QR code.

IMPORTANT NOTICE: All claims for warranty must be accompanied with the following three documents:

1. Copy of the Installation Receipt OR Tax Invoice OR Certificate of Compliance for the installation of the Martec product from the installing electrician
2. Copy of the Purchase Receipt for the Martec product
3. Submit an online warranty claim form. Please ensure that the purchaser's full name and contact details are clearly stated, in addition to the full nature of the fault and the product code.

It is the responsibility of the purchaser to keep the documents required for a warranty application of the warranty period.

Customer Service operates between 8AM to 4PM EST Monday to Friday.

Customer Service Number: (02) 8778 7500

